

B.Tech IV Year I Semester (R13) Supplementary Examinations June 2018
ESTIMATION, COSTING & VALUATION
 (Civil Engineering)

Time: 3 hours

Max. Marks: 70

PART – A
 (Compulsory Question)

- 1 Answer the following: (10 X 02 = 20 Marks)
- What is estimating? State two objectives of preparing estimation
 - State the units of following items: (i) Brick masonry. (ii) Plastering. (iii) DPC. (iv) Doors, windows, ventilators.
 - Tabulate formats neatly of detailed estimate and abstract estimate separately.
 - A single room building is having 3.60 m x 6.00 m internal dimensions with 300 mm thick wall and height of room is 2.30 m. Calculate: (i) Plinth area. (ii) Brick work for single room without considering of deductions for super structure.
 - Explain the terms 'Lead' and 'Lift' for the formation of roads and give the values initial lead and initial lift
 - Calculate the total length of the bar as shown in figure below.

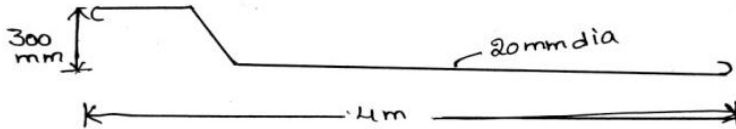

- List out the type of contracts.
- What is salvage value?
- Write short note on scrap value.
- Define valuation of building and its purpose.

PART – B

(Answer all five units, 5 X 10 = 50 Marks)

UNIT – I

- 2 Write down specifications for: (i) Painting. (ii) Plastering. (iii) RCC works. (iv) White washing.

OR

- 3 What is an approximate estimate? State the different approximate methods of estimating civil engineering structures.

UNIT – II

- 4 Work out the quantities for the following items for the figure shown below:

- Cement concrete (1:4:8) required for steps.
- Brick masonry required for steps.

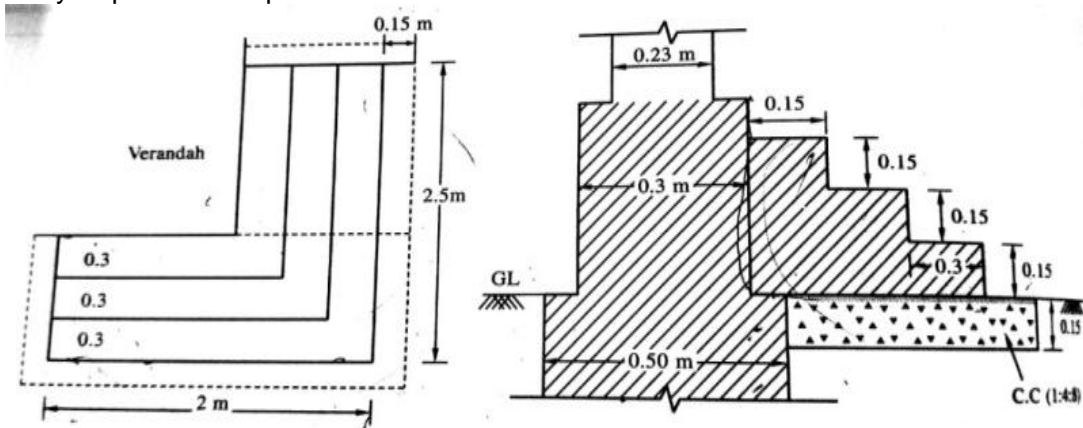

OR

Contd. in page 2

Code: 13A01701

- 5 Estimate the following quantities for the figure given below for following data:
- Earthwork in foundations.
 - Concrete in foundations.
 - Brick work in foundation and plinth in 1:6 cement mortar.
 - 2 cm damp proof course at plinth level.

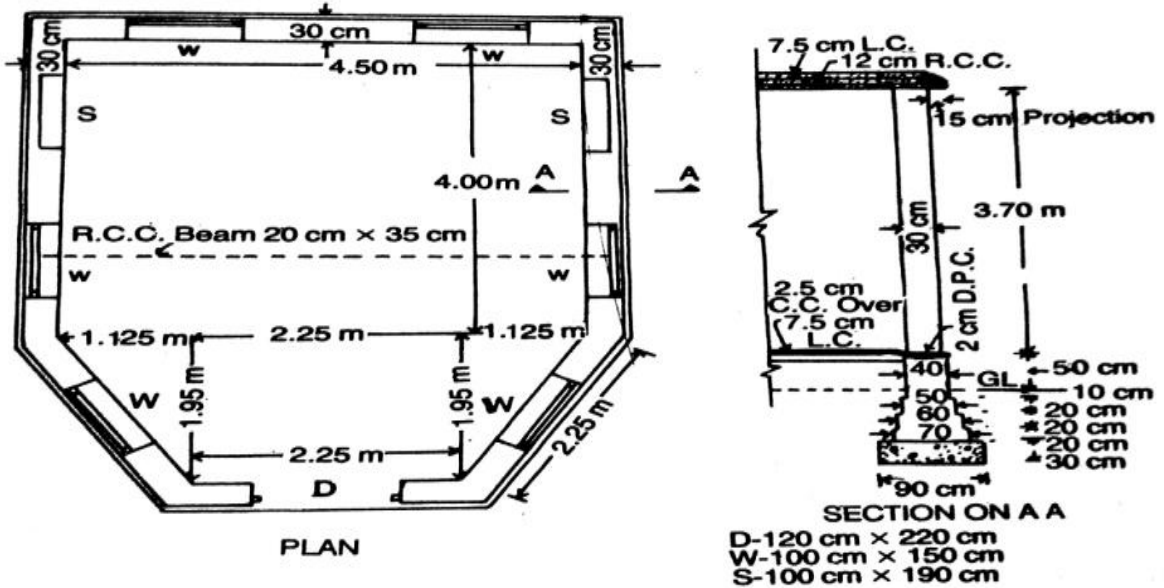

UNIT - III

- 6 A road embankment has the following data:

Chainage in m	0	30	60	90	120
G.L in m	131.75	130.96	132.60	133.35	133.50

Calculate the volume of earth work required given that the formation level is 134.00 m at all chainages and side slopes of the embankment are 2:1 and the top width is 15 m.

OR

- 7 Work out the quantity of reinforcement by preparing bar requirement schedule of a beam as per the drawing given below. Side covers 50 mm.

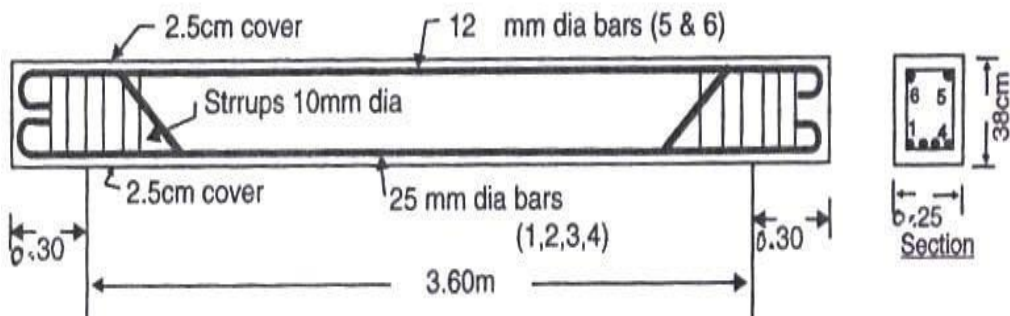

- 8 What are the contents of a tender document? Enumerate the complete tendering procedure with illustrations.

OR

- 9 Explain the contract system and the types of contracts in detail.

UNIT - V

- 10 List and explain general specifications of a second class building.

OR

- 11 Write detailed specifications of cement concrete (1:2: 4) for M20.
