

NETWORK ANALYSIS

(Common to ECE & EIE)

Time: 3 hours

Max. Marks: 70

PART - A
(Compulsory Question)

1 Answer the following: (10 X 02 = 20 Marks)

(a) Determine V_1 in the following network.

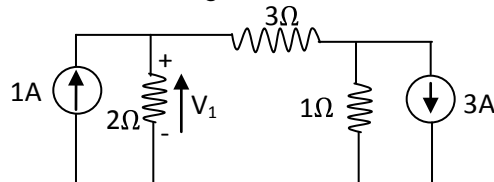

(b) Reduce the following network into a single source network.

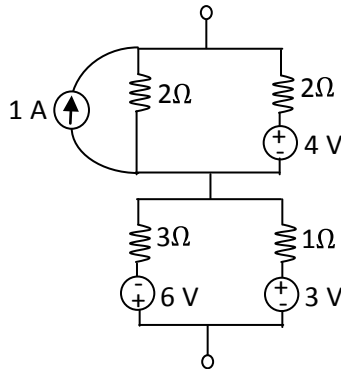

(c) A unit pulse of width 1 sec as shown is applied to an R – L series circuit with $R = 1 \Omega$ and $L = 1H$. Sketch the current response $i(t)$ in the circuit.

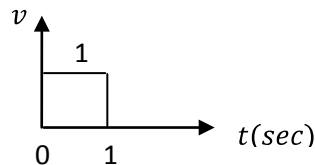

- (d) A DC source of 1V is suddenly applied to a series R-L-C circuit with $R = 2\Omega$, $L = 1H$ and $C = \frac{1}{2} F$. Sketch the current response $i(t)$ in the circuit.
- (e) A voltage source $V = 50 \sin 100t$ is applied to a series R-L-C circuit with $R = 10\Omega$, $L = 0.1H$ and $C = 100\mu F$. Determine the phase angle between the current and voltage phasors in steady state.
- (f) A voltage source $V = 100 \sin (\omega t + 45^\circ)$ volts is applied to a network resulting in a current $I = 50 \sin (\omega t + 75^\circ)$ amps. Find the average power consumed by the network.
- (g) A coil of impedance $R + j X_L$ is in parallel with a capacitor of $C = 10\mu F$. If $R = 10\Omega$ and $L=0.1H$ find the frequency at which it resonates, if connected to a variable frequency source.
- (h) Two coupled coils with self inductances of 1H and 2H are connected in series aiding. The resulting inductance L_{eq} is 4H. Find the coefficient of coupling between them.
- (i) When 10 V is applied to a two port resistive network, on no load, the voltage at the open circuit end is 8 V. When 1 amp load is connected, the voltage at the load end is 6 V. Find the voltage at the load end for a load current of 2 amp. The supply voltage is same in all the cases.
- (j) Draw the frequency response characteristics of a band pass filter and indicate the important frequencies in it.

PART - B

(Answer all five units, 5 X 10 = 50 Marks)

UNIT - I

- 2 In the network shown below, ammeter reads $\frac{4}{3}$ amps when the switch S is closed. Find the reading of the ammeter when the switch is opened.

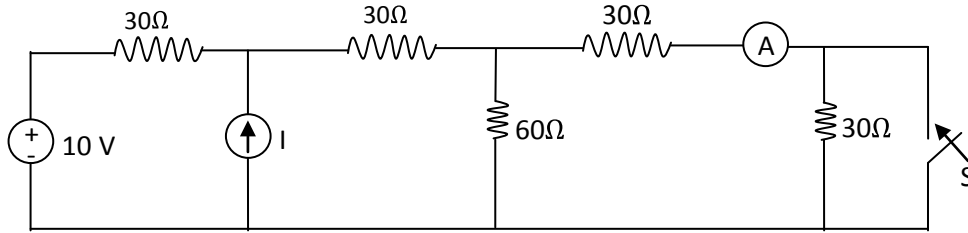

OR

- 3 (a) State and explain Thevenin's theorem.
 (b) In the following network determine R_L such that maximum power is delivered to it.

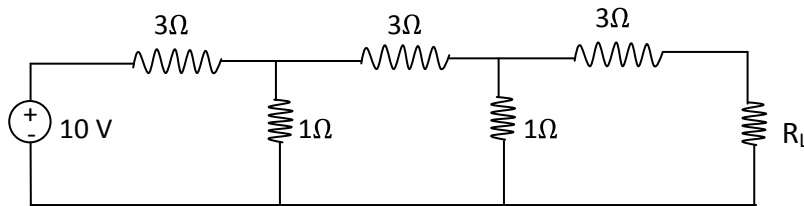

UNIT - II

- 4 In the following network, the switch S is open and steady state is reached. At $t = 0$, S is closed. Find $i_L(t)$ for $t > 0$.

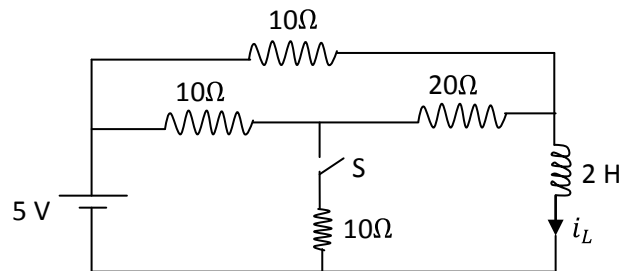

OR

- 5 The following network is in steady state with S open. At $t = 0$, S is closed. Find $i_C(t)$ for $t > 0$.

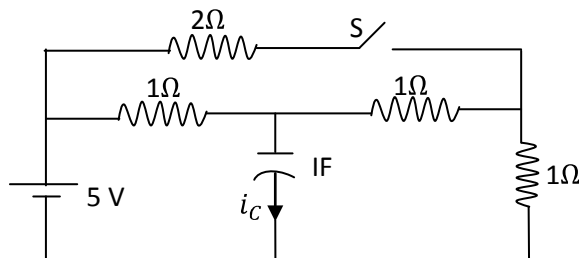

Contd. in page 3

UNIT - III

- 6 (a) A voltage source $V = 100 \sin(300t + 30^\circ)$ is applied to a network containing two elements in series. The resulting current $I = 20 \sin(300t - 30^\circ)$ amps. Determine the values of the two elements.
- (b) In the following network, determine the voltage across capacitor V_c .

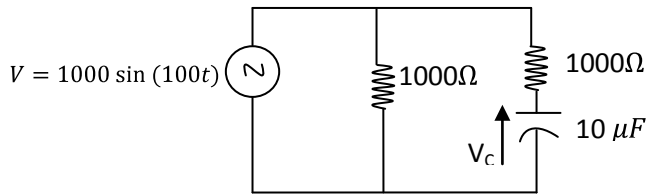

OR

- 7 (a) A voltage source $V = V_m \sin \omega t$ is applied to a series R-L circuit. Determine the expression for average power consumed.
- (b) In the following network determine the total power supplied by the source.

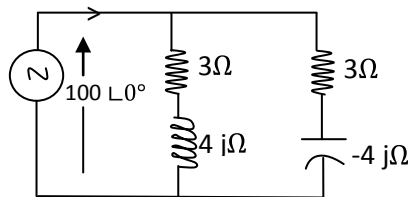

UNIT - IV

- 8 A coil of impedance $R + j X_L$ is connected in series with a 50Ω resistor and a capacitor $- j X_C$ ohms. The combination is connected across a 100 V variable frequency source. At a frequency of 200 Hz, maximum current of 0.7 amps flows in the circuit and the voltage across the capacitor is 200 volts at this frequency. Find R , X_L , X_C and band width of the circuit.

OR

- 9 In the following coupled circuit determine the current supplied by the source I .

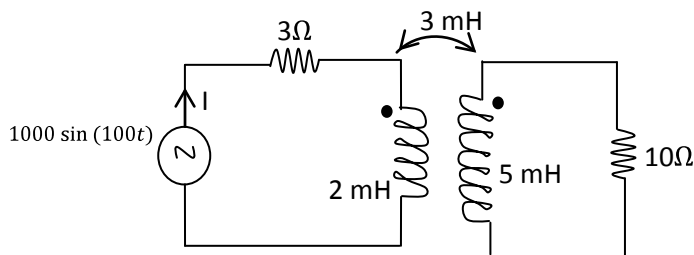

UNIT - V

- 10 Find the Y and Z parameters of the following two port resistive network. Verify the relation between them.

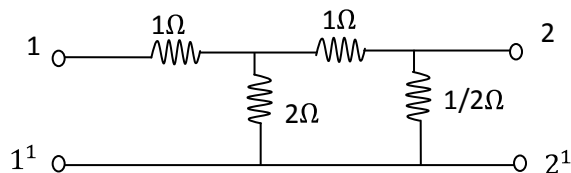

OR

- 11 (a) Describe the principle of constant K low pass filter and high pass filter.
- (b) Design a constant K low pass filter of T-type with a cut off frequency of 2 KHz with a load resistance termination of 500 ohms.